

OWNER'S MANUAL

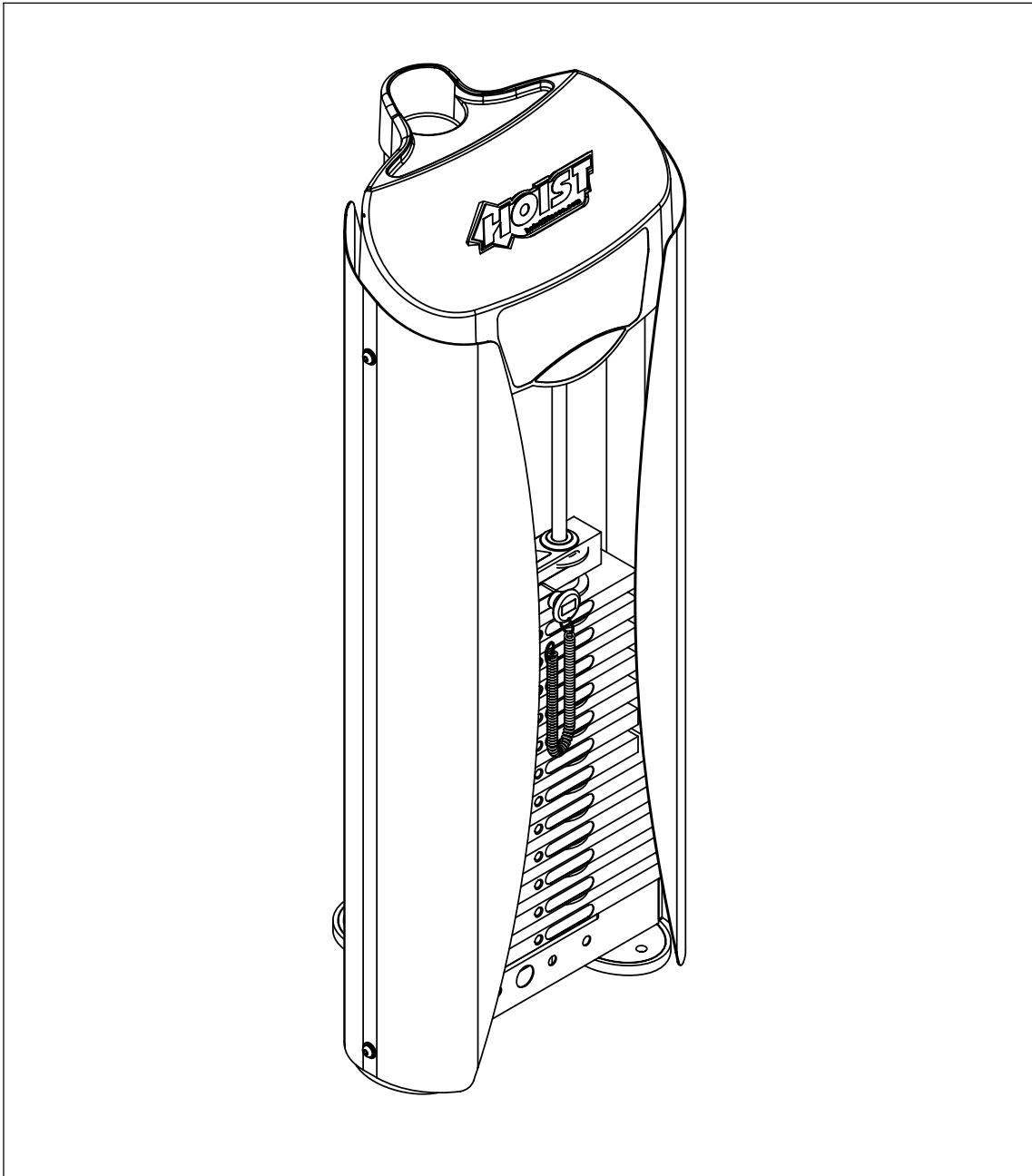

ROC-IT WEIGHT CAGE



Note: Both Serial Number and Model Number are Required when Ordering Parts

RECORD SERIAL NUMBER HERE

CATALOG NUMBER

0406 - 0010

Customer Service

(800) 548-5438

(858) 578-7676

Fax

(858) 578-9558

OWNER'S MANUAL

CONTENTS

INSTRUCTIONS	02
FRAME ASSEMBLY	03
WEIGHT STACK CONFIGURATIONS.....	04
PRE-ASSEMBLY.....	20
DECAL PLACEMENT.....	21
DECAL REFERENCE.....	22
PART LIST.....	23
ABBREVIATIONS.....	24
BOLT SIZING CHART.....	25
WASHER SIZING CHART.....	27
GENERAL MAINTENANCE INFORMATION.....	29
MAINTENANCE SCHEDULE.....	31
WEIGHT TRAINING TIPS.....	32
EXERCISE LOG.....	33
LIMITED WARRANTY.....	34

OWNER'S MANUAL

INSTRUCTIONS

Before beginning assembly please take the time to read instructions thoroughly. Please use the various lists in this manual to make sure that all parts have been included in your shipment. When ordering, use part number and description from the lists. Use only HOIST replacement parts when servicing. Failure to do so will void your warranty and could result in personal injury.

HOIST equipment is designed to provide the smoothest, most effective exercise motion possible. After assembly, you should check all functions to ensure correct operation. If you experience problems, first recheck the assembly instructions to locate any possible errors made during assembly. If you are unable to correct the problem, call your authorized HOIST dealer. Be sure to have your serial number and this manual when calling. When all parts have been accounted for, continue on.

TOOLS REQUIRED

Ratchet Wrench

1/2", 9/16" and 3/4" Sockets

Adjustable Wrench

Rubber Mallet

Tape Measure

Level

Hex Key Wrench Set

OWNER'S MANUAL

FRAME ASSEMBLY

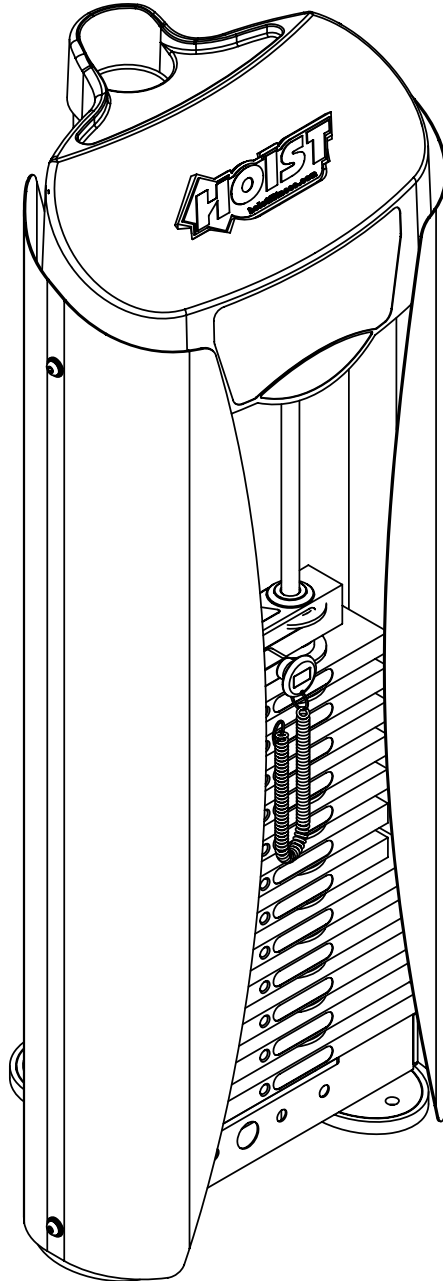

OWNER'S MANUAL

WEIGHT STACK CONFIGURATIONS

	CIRCUIT STACK #1	CIRCUIT STACK #2	CIRCUIT STACK #2 W/ STAND OFFS	CIRCUIT STACK #3	CIRCUIT STACK #4 W/ STAND OFFS	CIRCUIT STACK #5
ROC-IT 101 SEATED DIP						
ROC-IT 102 BICEPS CURL						
ROC-IT 201 PULLDOWN						
ROC-IT 203 SEATED MID ROW						
ROC-IT 301 CHEST PRESS						
ROC-IT 401 LEG EXTENSION						
ROC-IT 402 LEG CURL						
ROC-IT 403 LEG PRESS						
ROC-IT 501 SHOULDER PRESS						

OWNER'S MANUAL

FRAME ASSEMBLY

NOTE:

- HAND TIGHTEN HARDWARE.
- INSTALL **CABLE** AND PULLEYS AT THE SAME TIME.

* - REFER TO MACHINE MANUAL FOR **CABLE** NUMBER AND LENGTH.

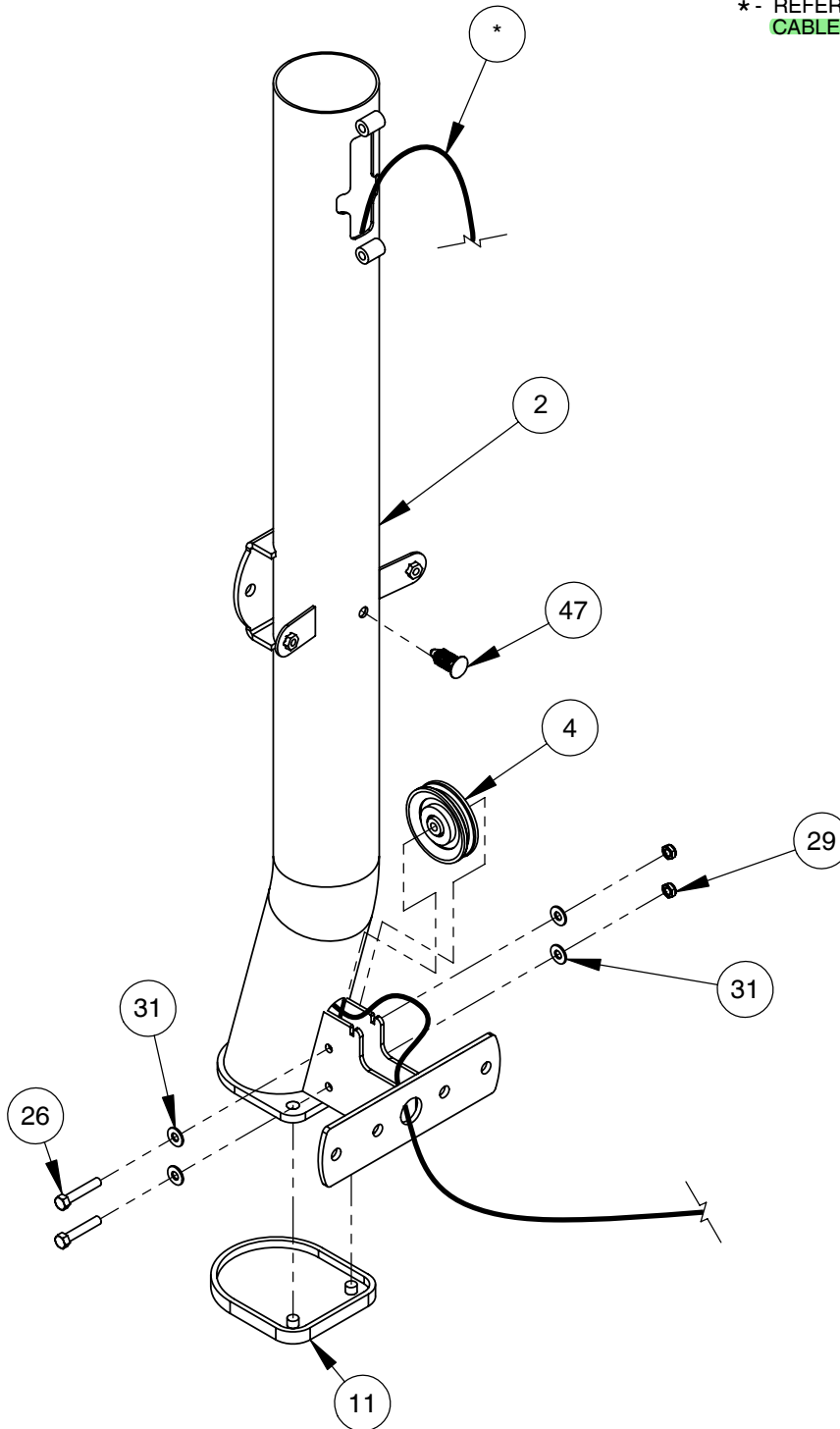

OWNER'S MANUAL

FRAME ASSEMBLY

- NOTES:
- WRENCH TIGHTEN HARDWARE.
- SOME PARTS MAY HAVE BEEN
REMOVED FOR CLARITY.

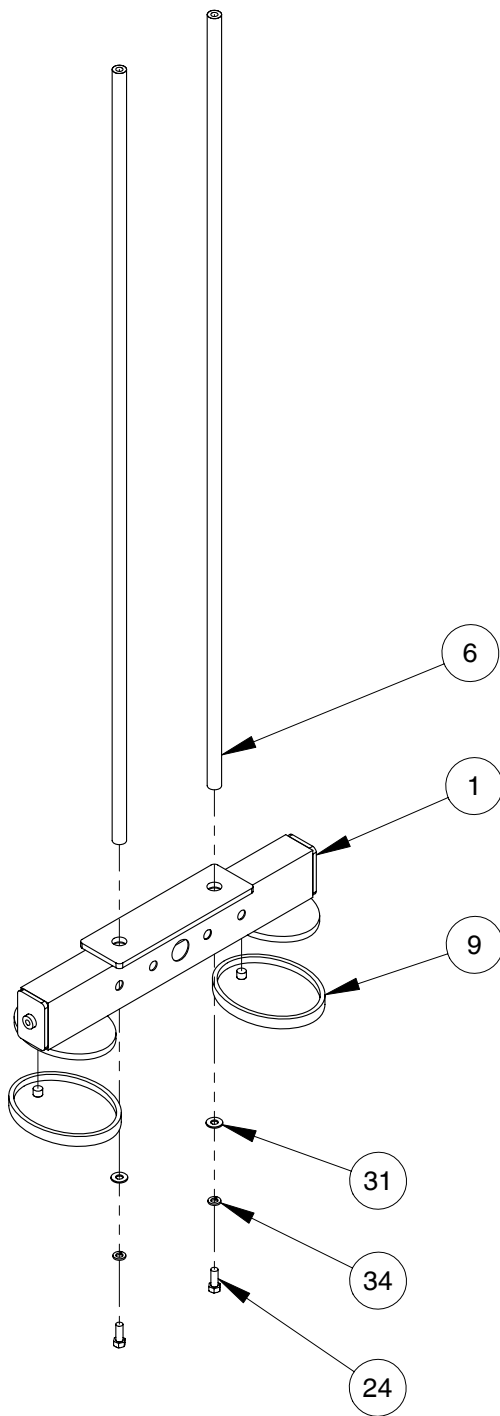

OWNER'S MANUAL

FRAME ASSEMBLY

- NOTES:
- REFERENCE FIRST STEP OF FRAME
* ASSEMBLY IN MACHINE MANUAL,
FOR HARDWARE AND PROPER
ORIENTATION OF CROSS MEMBER.

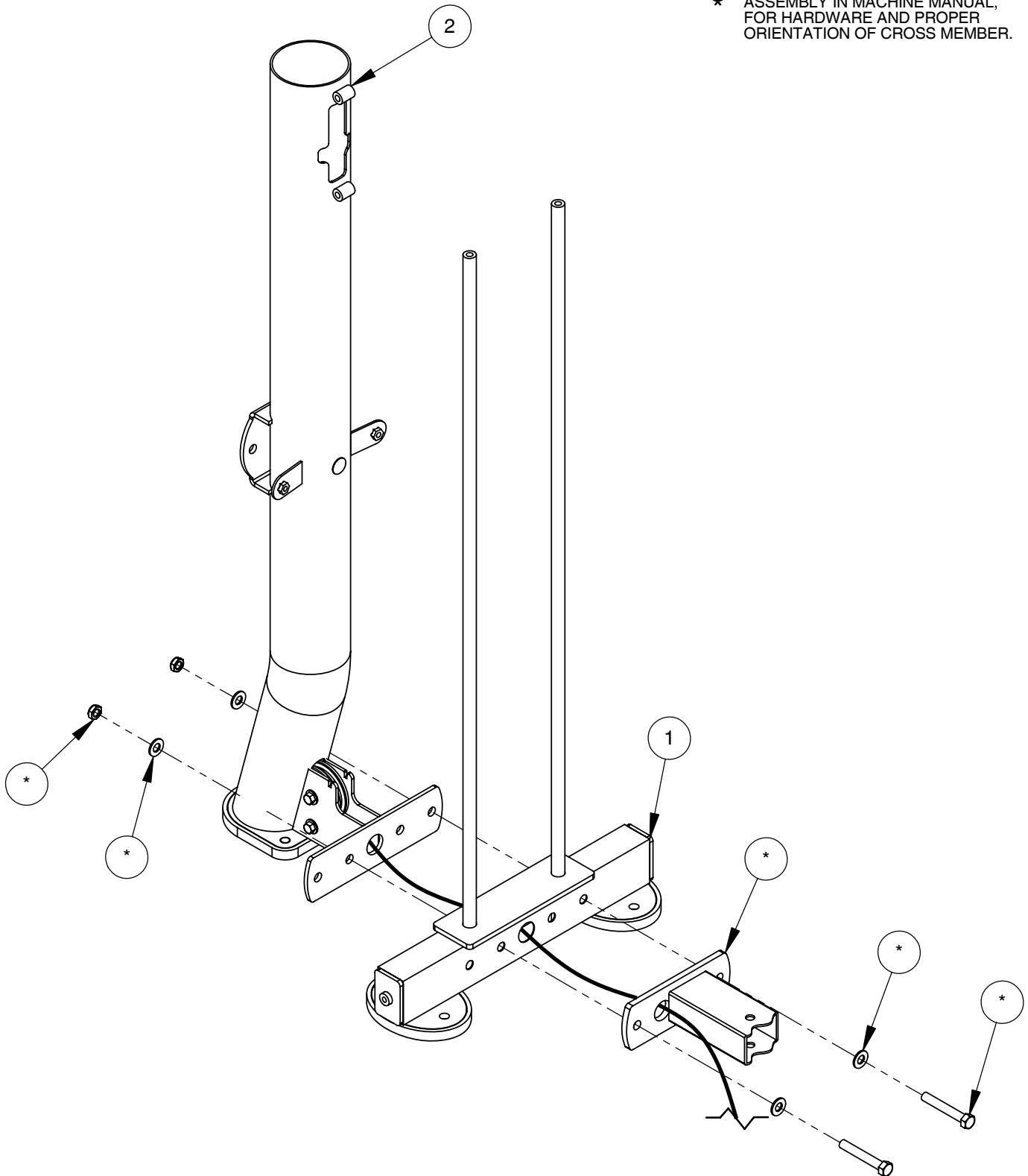

OWNER'S MANUAL

FRAME ASSEMBLY CIRCUIT WEIGHT STACK #1

ITEM NO.	PART NUMBER	DESCRIPTION	QTY.
5	019-0001006	Ø3.00" X .50" THICK RUBBER DONUT BLACK	2
6	026-01G0193	GUIDE ROD Ø.750" X 49.078" LG.	2
15	026-01X2872	8 LB TOP WEIGHT PLATE ASSEMBLY	1
18	026-01PL0348	WEIGHT PLATE SPACER .563" THICK	24
20	026-01W0312	15 LB INTERMEDIATE WEIGHT PLATE	7
21	026-01W0315	20 LB INTERMEDIATE WT. PLATE	5

NOTE:

- THE FOLLOWING MACHINES USE
THIS WEIGHT PLATE ARRANGEMENT:

- **ROC-IT 501, SHOULDER PRESS**

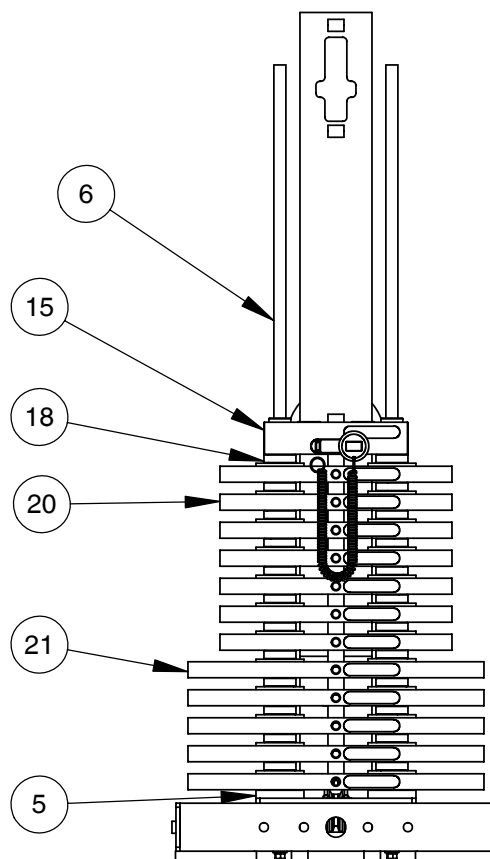
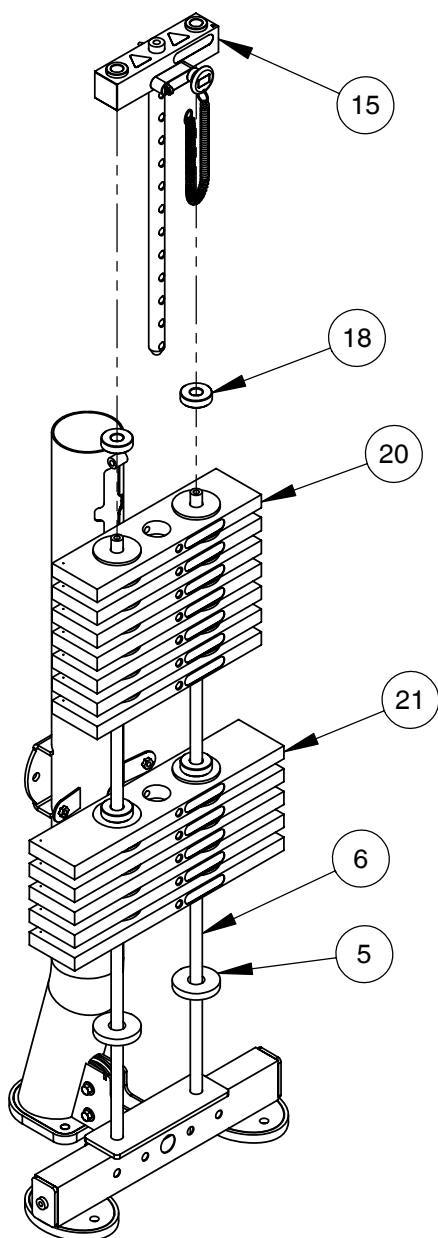

ASSEMBLY FRONT VIEW

OWNER'S MANUAL

FRAME ASSEMBLY CIRCUIT WEIGHT STACK #2

ITEM NO.	PART NUMBER	DESCRIPTION	QTY.
5	019-0001006	Ø 3.00" X .50" THICK RUBBER DONUT BLACK	2
6	026-01G0193	GUIDE ROD Ø.750" X 49.078" LG.	2
16	026-01X2873	15 LB TOP WEIGHT PLATE ASSEMBLY	1
18	026-01PL0348	WEIGHT PLATE SPACER .563" THICK	24
20	026-01W0312	15 LB INTERMEDIATE WEIGHT PLATE	7
21	026-01W0315	20 LB INTERMEDIATE WEIGHT PLATE	5

NOTE:

- THE FOLLOWING MACHINES USE THIS WEIGHT PLATE ARRANGEMENT:

- ROC-IT 101, SEATED DIP
- ROC-IT 102, BICEPS CURL
- ROC-IT 201, PULLDOWN
- ROC-IT 203, SEATED MID-ROW

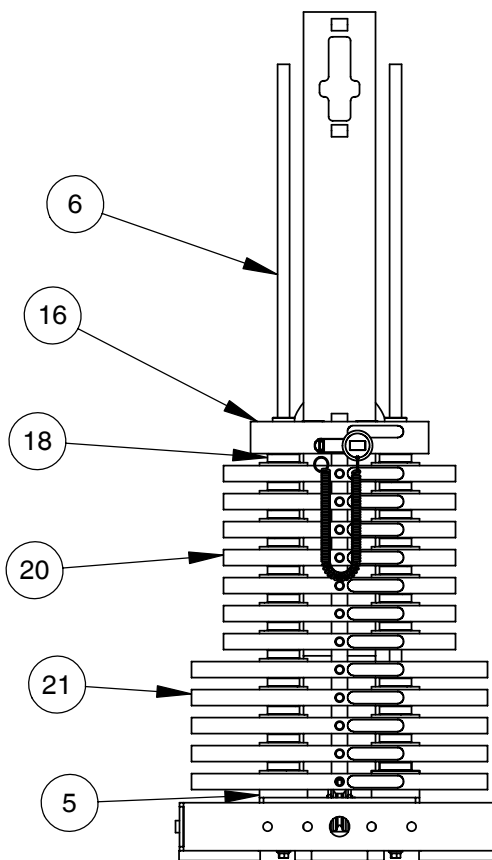
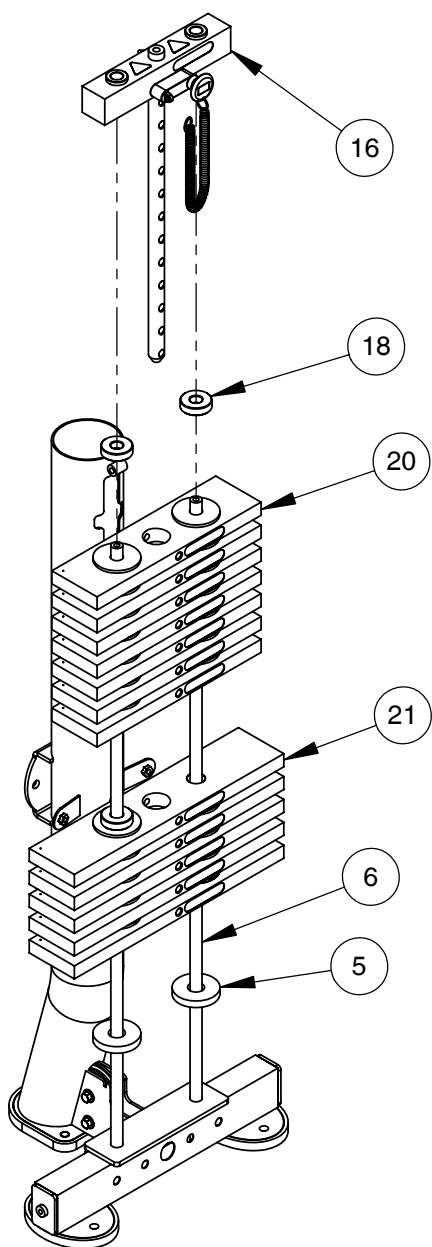

ASSEMBLY FRONT VIEW

OWNER'S MANUAL

FRAME ASSEMBLY CIRCUIT WEIGHT STACK #2 WITH STAND OFFS

ITEM NO.	PART NUMBER	DESCRIPTION	QTY.
5	019-0001006	Ø 3.00" X .50" THICK RUBBER DONUT BLACK	2
6	026-01G0193	GUIDE ROD Ø.750" X 49.078" LG.	2
8*	026-01PL0369	WEIGHT STAND OFF	2
16	026-01X2873	15 LB TOP WEIGHT PLATE ASSEMBLY	1
18	026-01PL0348	WEIGHT PLATE SPACER .563" THICK	24
20	026-01W0312	15 LB INTERMEDIATE WEIGHT PLATE	7
21	026-01W0315	20 LB INTERMEDIATE WT. PLATE	5

NOTE:

- * PART FOUND IN MACHINE BOX.
- THE FOLLOWING MACHINES USE THIS WEIGHT PLATE ARRANGEMENT:

- ROC-IT 401, LEG EXTENSION

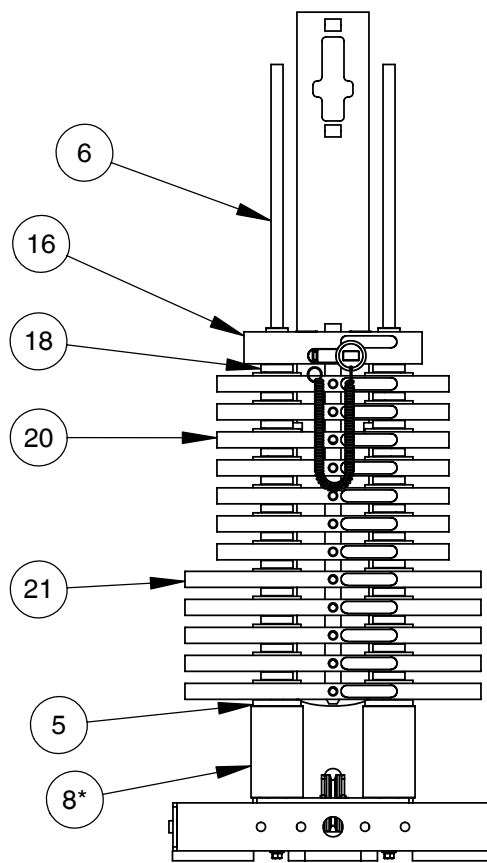
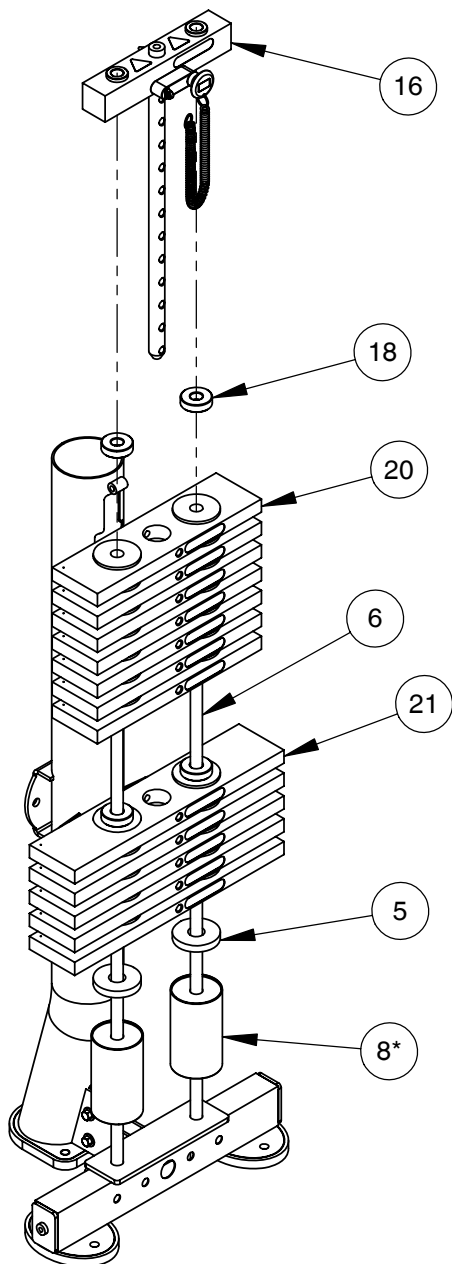

ASSEMBLY FRONT VIEW

OWNER'S MANUAL

FRAME ASSEMBLY CIRCUIT WEIGHT STACK #3

ITEM NO.	PART NUMBER	DESCRIPTION	QTY.
5	019-0001006	Ø 3.00" X .50" THICK RUBBER DONUT BLACK	2
6	026-01G0193	GUIDE ROD Ø .750" X 49.078" LG.	2
15	026-01X2872	8 LB TOP WEIGHT PLATE ASSEMBLY	1
18	026-01PL0348	WEIGHT PLATE SPACER .563" THICK	24
20	026-01W0312	15 LB INTERMEDIATE WEIGHT PLATE	3
21	026-01W0315	20 LB INTERMEDIATE WT. PLATE	9

NOTE:
- THE FOLLOWING MACHINES USE
THIS WEIGHT PLATE ARRANGEMENT:

- ROC-IT 301, CHEST PRESS

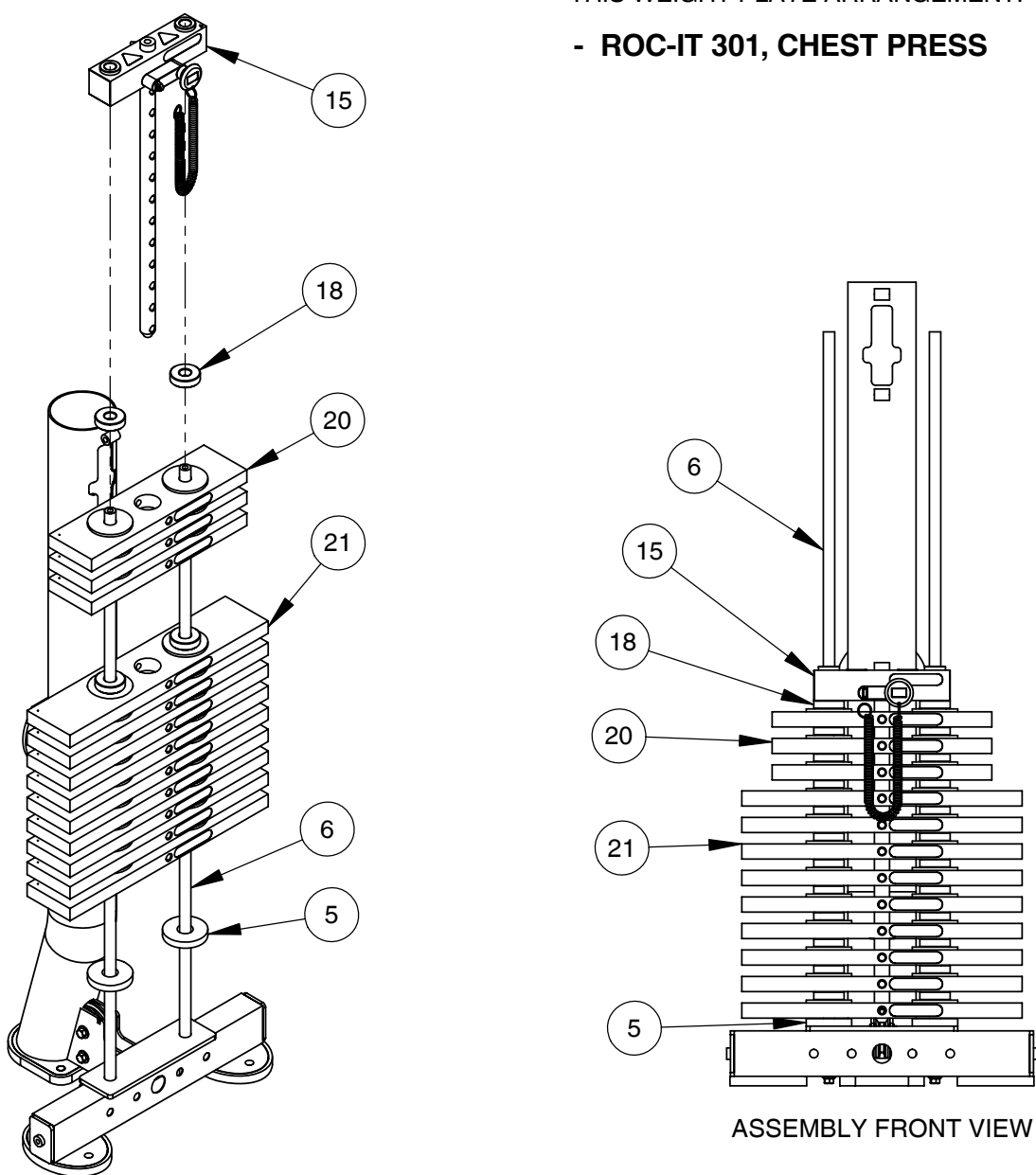

OWNER'S MANUAL

FRAME ASSEMBLY CIRCUIT WEIGHT STACK # 4 WITH STAND OFFS

ITEM NO.	PART NUMBER	DESCRIPTION	QTY.
5	019-0001006	Ø 3.00" X .50" THICK RUBBER DONUT BLACK	2
6	026-01G0193	GUIDE ROD Ø .750" X 49.078" LG.	2
8*	026-01PL0369	WEIGHT STAND OFF	2
18	026-01PL0348	WEIGHT PLATE SPACER .563" THICK	24
20	026-01W0312	15 LB INTERMEDIATE WEIGHT PLATE	7
21	026-01W0315	20 LB INTERMEDIATE WT. PLATE	5
44	026-01X3036	30 LB TOP WEIGHT PLATE ASSEMBLY	1

NOTE:
 * PART FOUND IN MACHINE BOX.
 - THE FOLLOWING MACHINES USE
 THIS WEIGHT PLATE ARRANGEMENT:

- ROC-IT 402, LEG CURL

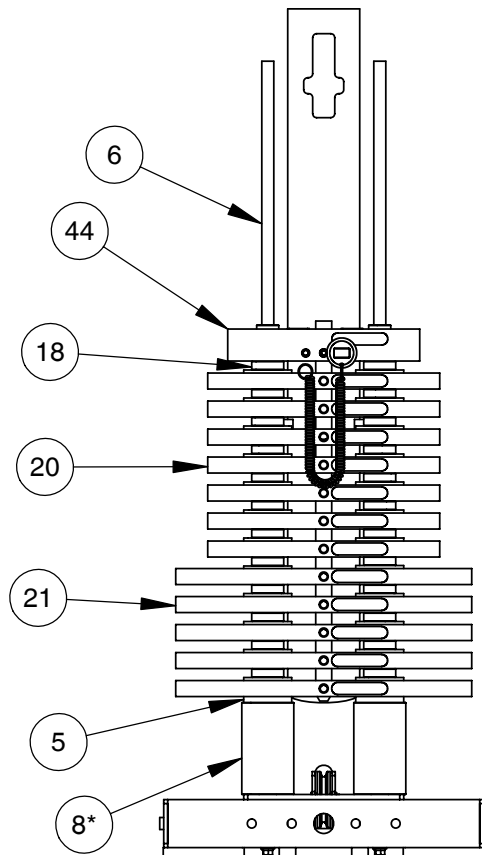
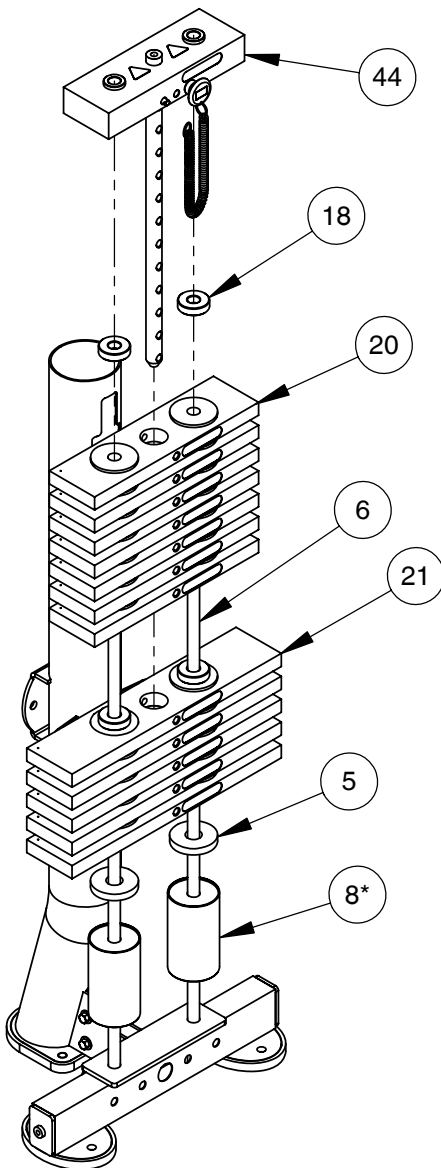

OWNER'S MANUAL

FRAME ASSEMBLY CIRCUIT WEIGHT STACK # 5

ITEM NO.	PART NUMBER	DESCRIPTION	QTY.
6	026-01G0193	GUIDE ROD ϕ .750" X 49.078" LG.	2
17	026-01X2874	40 LB TOP WEIGHT PLATE ASSEMBLY W/ 18 HOLE STEM	1
21	026-01W0315	20 LB INTERMEDIATE WEIGHT PLATE	17
22	026-01PL2176	ϕ 3.00" OD X ϕ .781" ID X .813" THICK SPACER	2

NOTE:
- THE FOLLOWING MACHINES USE
THIS WEIGHT PLATE ARRANGEMENT:

- ROC-IT 403, LEG PRESS

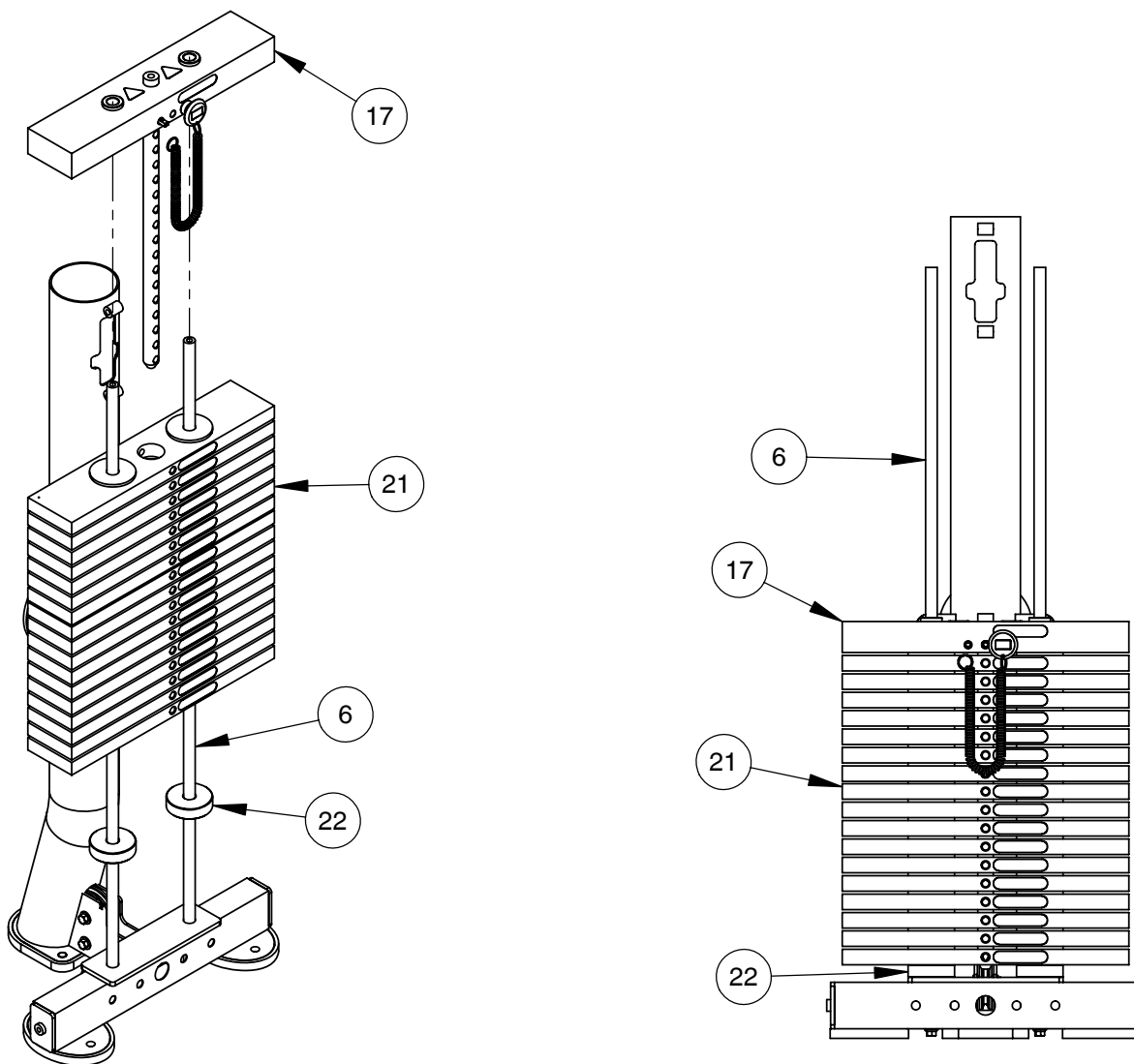

OWNER'S MANUAL

THIS PAGE WAS INTENTIONALLY LEFT BLANK

OWNER'S MANUAL

FRAME ASSEMBLY

NOTE:

- WRENCH TIGHTEN HARDWARE.
- SOME PARTS MAY HAVE BEEN REMOVED FOR CLARITY.
- INSTALL **CABLE** AND PULLEYS AT THE SAME TIME.

*- ACTUAL WEIGHT STACK MAY VARY. REFER TO PAGE O4.

** - BE SURE **CABLE** RUNS BETWEEN THE PULLEYS AND THE GUARD PIN.

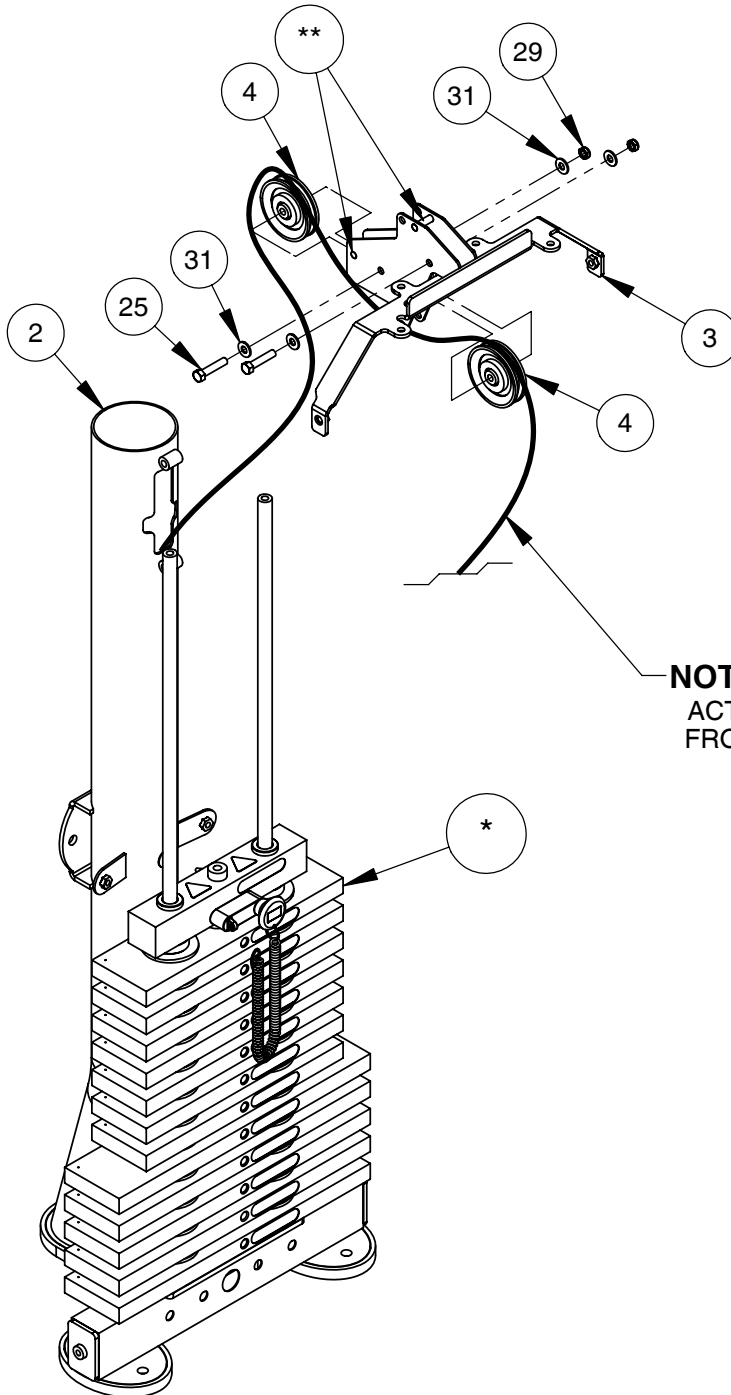

NOTICE:

ACTUAL **CABLE** WILL COME FROM MACHINE BOX.

OWNER'S MANUAL

FRAME ASSEMBLY

- NOTE:
- WRENCH TIGHTEN HARDWARE.
* - ACTUAL WEIGHT STACK MAY VARY. REFER TO PAGE 04.

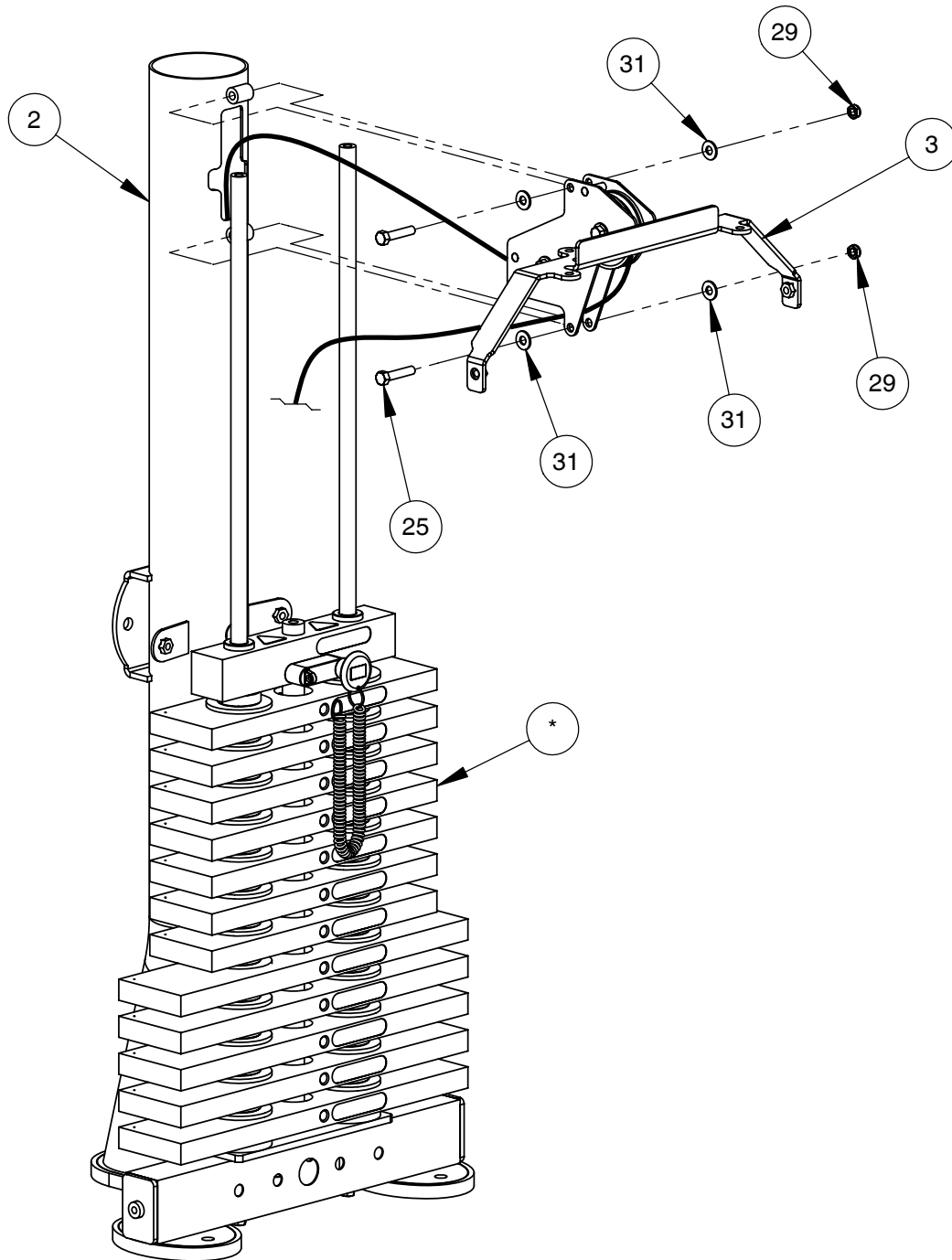

OWNER'S MANUAL

FRAME ASSEMBLY

NOTE:

- WRENCH TIGHTEN HARDWARE.
- * - ACTUAL WEIGHT STACK AND **CABLE** MAY VARY. REFER TO MACHINE MANUAL FOR CORRECT ITEMS.

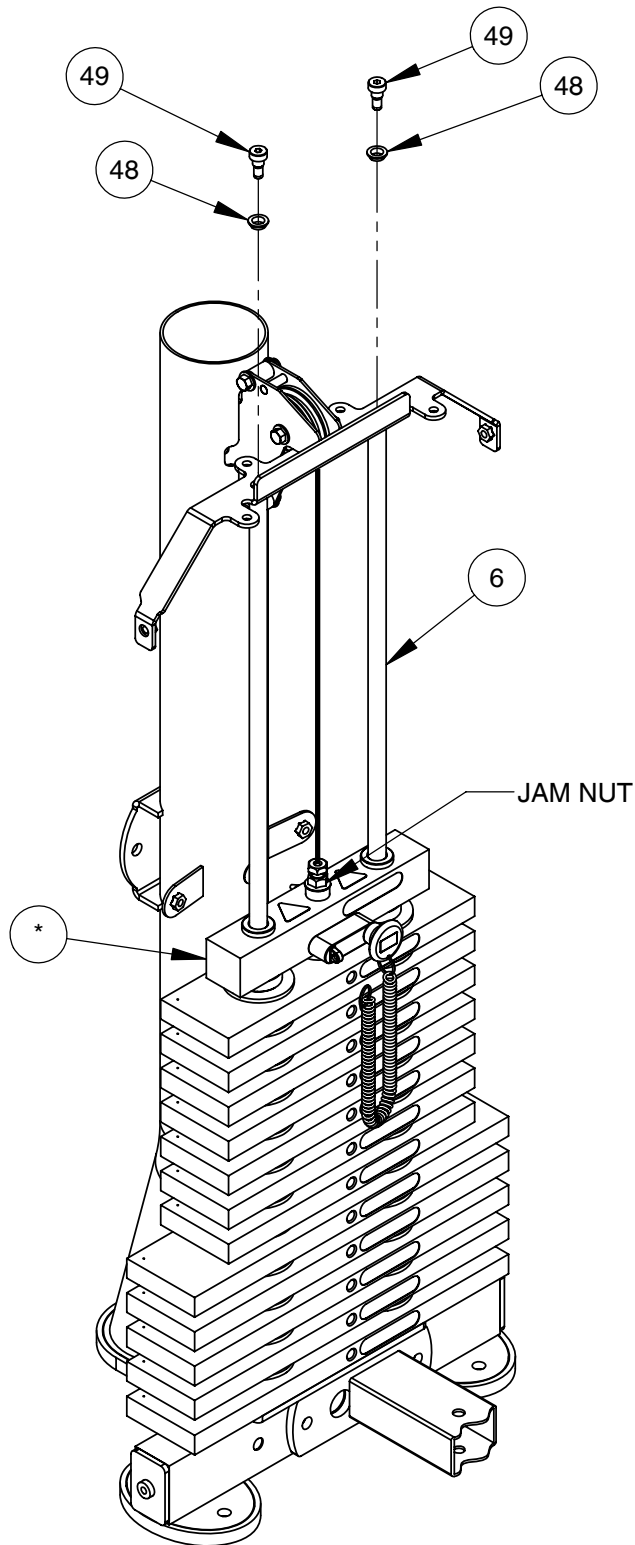

FINE TUNING:

LOOSEN JAM NUT AND THREAD BOLT IN/OUT TO GIVE THE **CABLE** PROPER TENSION. RE-TIGHTEN JAM NUT.

WARNING - **CABLE BOLT MUST BE THREADED A MINIMUM OF 3/8" WITH JAM NUT TIGHTENED SECURELY TO ENSURE PROPER CONNECTION.**

STOP!

PRIOR TO COMPLETING WEIGHT CAGE ASSEMBLY, REFER TO MACHINE MANUAL FOR MACHINE ASSEMBLY.

OWNER'S MANUAL

FRAME ASSEMBLY

NOTE:
- WRENCH TIGHTEN HARDWARE.
* - ACTUAL WEIGHT STACK AND **CABLE** MAY VARY. REFER TO MACHINE MANUAL FOR CORRECT ITEMS.

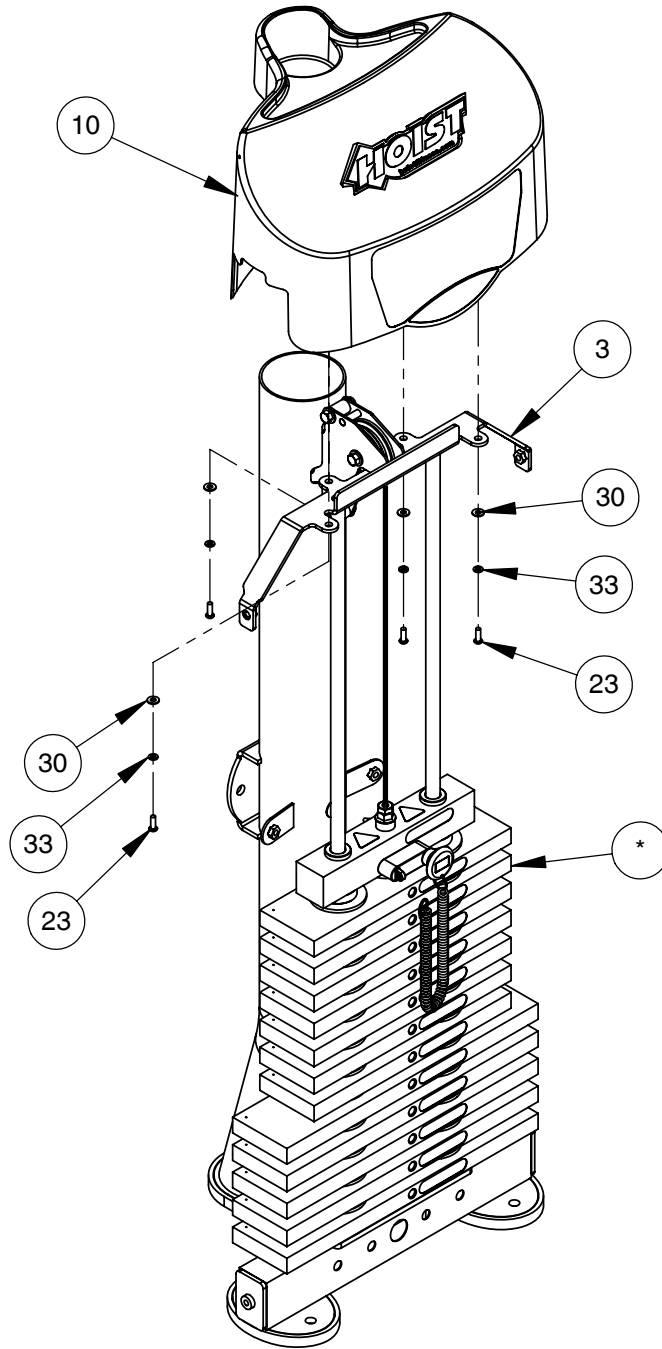

OWNER'S MANUAL

FRAME ASSEMBLY

- NOTES:
- WRENCH TIGHTEN HARDWARE.
* - ACTUAL WEIGHT STACK AND **CABLE** MAY VARY. REFER TO MACHINE MANUAL FOR CORRECT ITEMS.

HOIST RECOMENDS THE TOWEL HANGER BE INSTALLED ON THE SIDE OF THE WEIGHT CAGE MOST CONVIENT FOR THE END USER

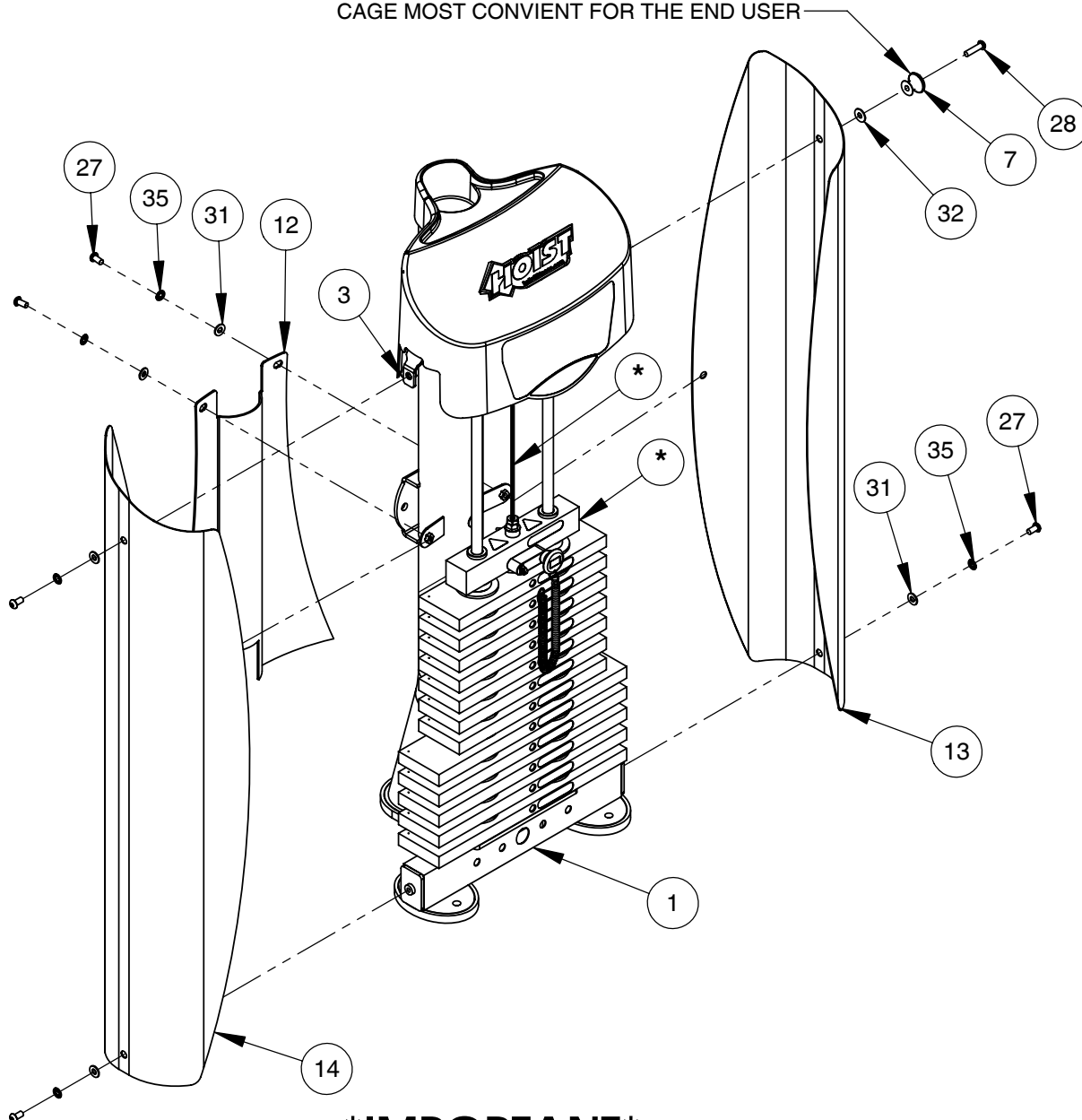

IMPORTANT

NOW THAT THE ROC-IT WEIGHT CAGE IS COMPLETELY ASSEMBLED, TAKE TIME TO ENSURE THAT YOUR UNIT IS ASSEMBLED SQUARE AND PERPENDICULAR. USE A LEVEL TO CHECK THAT THE GUIDE RODS ARE PERPENDICULAR IN BOTH DIRECTIONS. IF THEY ARE NOT PERPENDICULAR IN BOTH DIRECTIONS, IT WILL BE NECESSARY TO LOOSEN SOME FRAME HARDWARE TO RE-ALIGN THE FRAME AND RETIGHTEN BOLTS.

OWNER'S MANUAL

PRE-ASSEMBLY

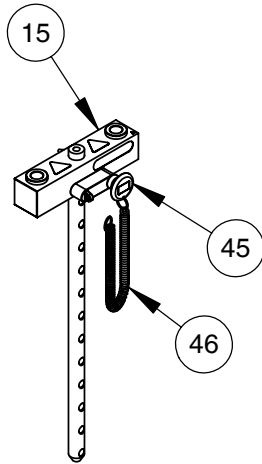

WEIGHT PLATE ASSEMBLY USED ON:

- ROC-IT 301, CHEST PRESS
- ROC-IT 501, SHOULDER PRESS

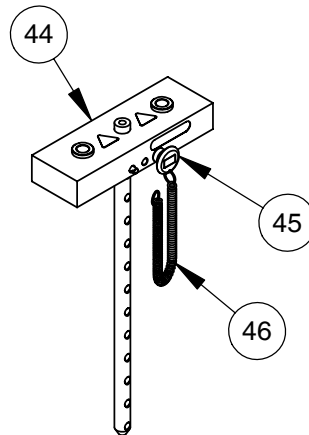

WEIGHT PLATE ASSEMBLY USED ON:

- ROC-IT 402, LEG CURL

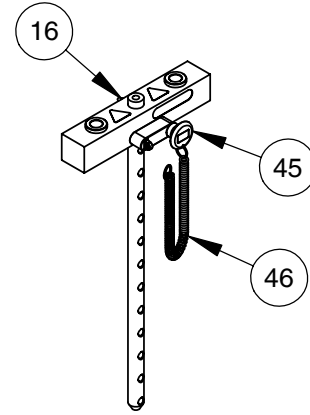

WEIGHT PLATE ASSEMBLY USED ON:

- ROC-IT 101, SEATED DIP
- ROC-IT 102, BICEPS CURL
- ROC-IT 201, LAT PULLDOWN
- ROC-IT 203, SEATED MID ROW
- ROC-IT 301, CHEST PRESS
- ROC-IT 401, LEG EXTENSION

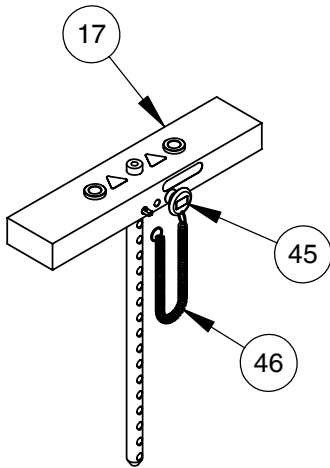

WEIGHT PLATE ASSEMBLY USED ON:

- ROC-IT 403, LEG PRESS

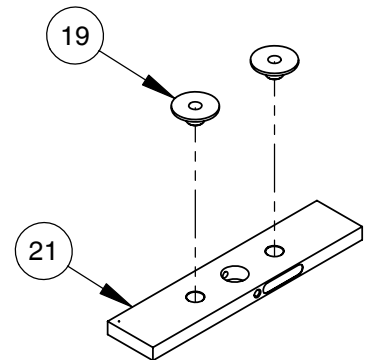
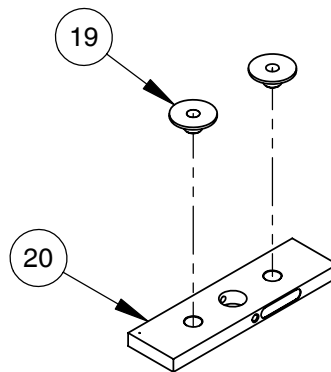

OWNER'S MANUAL

DECAL PLACEMENT

- NOTES:
- ALL DECALS ARE CENTERED UNLESS OTHERWISE STATED.
- SOME PARTS MAY HAVE BEEN REMOVED FOR CLARITY.

SPACED $\frac{1}{4}$ " BELOW, AND PARALLEL WITH TOP EDGE OF SHIELD, BOTH SIDES

BOTTOM EDGE OF DECAL $37\frac{1}{2}$ " FROM FLOOR AND $\frac{1}{8}$ " FROM INSIDE SHIELD EDGE.

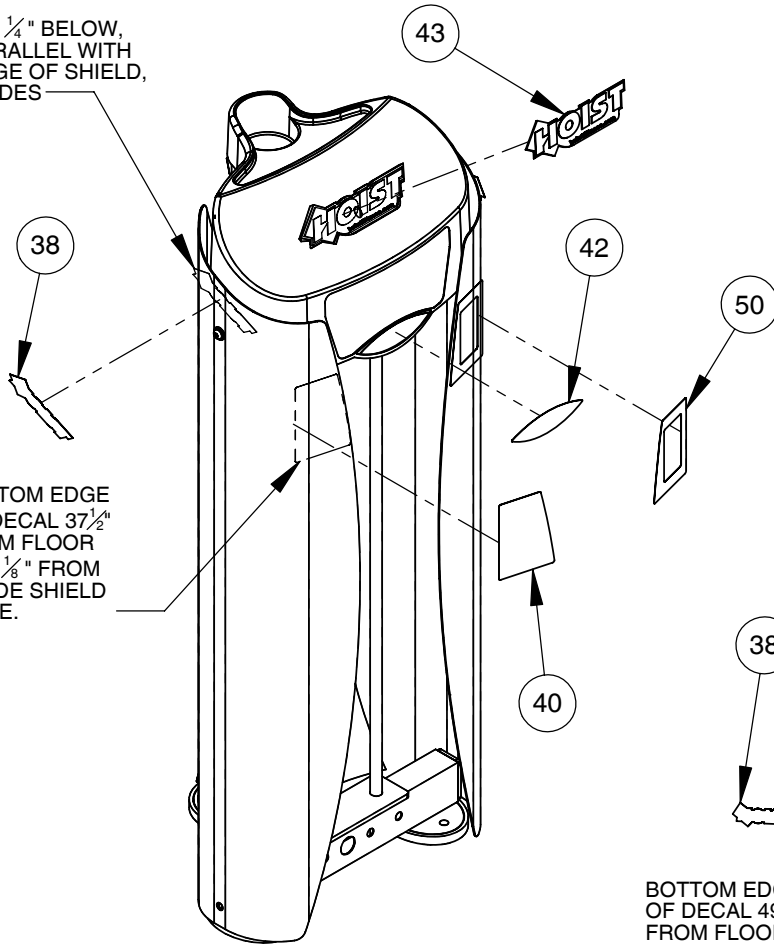

BOTTOM EDGE OF DECAL $49\frac{1}{4}$ " FROM FLOOR.

BOTTOM EDGE OF DECAL 35" FROM FLOOR.

BOTTOM EDGE OF DECAL 4" FROM FLOOR.

BOTTOM EDGE OF DECAL $1\frac{1}{2}$ " FROM FLOOR.

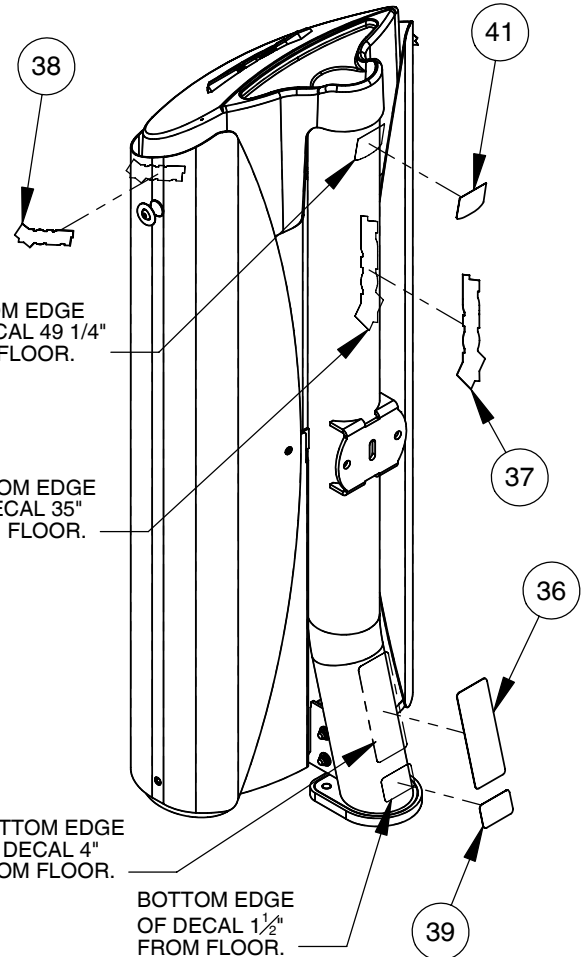

OWNER'S MANUAL

DECAL REFERENCE



021-0018022



021-0003221



021-0003230

COMMERCIAL MAINTENANCE	Daily	Weekly	Monthly	6 Months	Yearly
Inspect: Links, Pull Pins, Snap Locks, Swivels, Weight Stack Pins	X				
Clean: Upholstery	X				
Inspect: Cables or Belts and their tension	X				
Inspect: Accessory Bars and Handles		X			
Inspect: All Decals		X			
Inspect: All Nuts and Bolts, Tighten if Needed		X			
Inspect: Anti-Skid Surfaces		X			
Clean & Lubricate; Guide Rods with a Teflon (PTFE) based lubricant (Superlube)			X		
Lubricate; Seat Slides, Trolley Bushings, Linear Bearings			X		
Clean and Wax; All Glossy Finishes				X	
Repack with Grease; Linear Bearings				X	
Replace; Cables, Belts and Connecting Parts					X

021-0003573

(LOGO DECAL)
PLEASE CALL HOIST FOR PERSONALIZED
LOGO DECAL PURCHASING INFORMATION

021-0003552



021-0003405

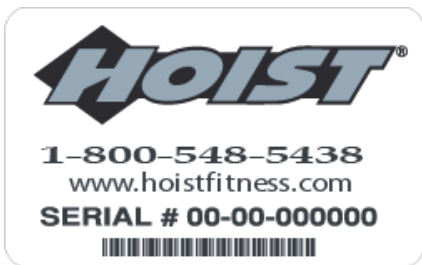

SERIAL # DECAL

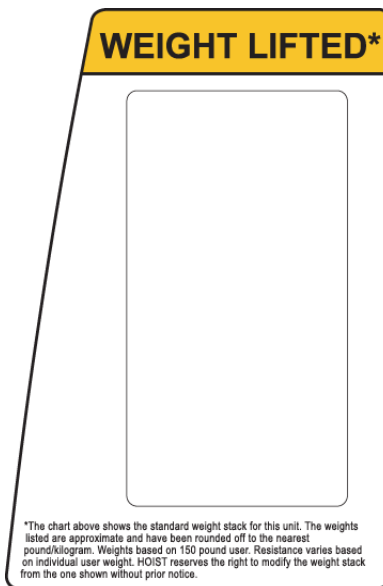

*The chart above shows the standard weight stack for this unit. The weights listed are approximate and have been rounded off to the nearest pound/kilogram. Weights based on 150 pound user. Resistance varies based on individual user weight. HOIST reserves the right to modify the weight stack from the one shown without prior notice.

021-0003571



021-0003344

OWNER'S MANUAL

PART LIST

NOTE: SOME OF THESE PARTS MAY COME PRE-INSTALLED, AND ACTUAL WEIGHT STACK COUNT MAY VARY. REFER TO MACHINE MANUAL FOR CORRECT QUANTITY.

ITEM NO.	PART NUMBER	DESCRIPTION	QTY.
1	026-01X2378	BOTTOM GUIDE ROD MOUNT	1
2	026-01X2411	BACK BONE ASSEMBLY	1
3	026-01X2453	TOP GUIDE ROD MOUNT	1
4	018-0001002	Ø3.50" CABLE PULLEY	3
5	019-0001006	Ø3.00" X .50" THICK RUBBER DONUT BLACK	2
6	026-01G0193	GUIDE ROD Ø.750" X 49.078" LG.	2
7	026-01M1013	Ø1.50" TOWEL HANGER	1
8	026-01PL0369	WEIGHT STAND OFF	2
9	026-01PL2122	OVAL-SHAPED RUBBER FOOT	2
10	026-01PL2127	TOP CAP	1
11	026-01PL2131	D-SHAPED RUBBER FOOT	1
12	026-01PL2153	PLASTIC SHIELD	1
13	026-1100212	SHIELD - RIGHT	1
14	026-1100213	SHIELD - LEFT	1
15	026-01X2872	8 LB TOP WEIGHT PLATE ASSEMBLY	1
16	026-01X2873	15 LB TOP WEIGHT PLATE ASSEMBLY	1
17	026-01X2874	40 LB TOP WEIGHT PLATE ASSEMBLY W/ 18 HOLE STEM	1
18	026-01PL0348	WEIGHT PLATE SPACER .563" THICK	24
19	026-01W0122	WEIGHT PLATE BUSHING	24
20	026-01W0312	15 LB INTERMEDIATE WEIGHT PLATE	7
21	026-01W0315	20 LB INTERMEDIATE WEIGHT PLATE	17
22	026-01PL2176	Ø3.00" OD X Ø.781" ID X .813" THICK SPACER	2
23	011-0102008	1/4"-20UNC X.75" BHCS (WZ)	4
24	011-0407022	3/8"-16UNC X 1.00" HHB (WZ)	2
25	011-0407020	3/8"-16UNC X 1.75" HHB (WZ)	4
26	011-0407058	3/8"-16UNC X 2.00" HHB (WZ)	2
27	011-0101005	3/8"-16UNC X .75" BHCS (WZ)	5
28	011-0101027	3/8"-16UNC X 1.50" BHCS (WZ)	1
29	012-0104008	3/8"-16 UNC THIN NYLOCK NUT (WZ)	6
30	013-0002003	1/4" X 16mm SAE FLAT WASHER (WZ)	4
31	013-0402007	3/8" X 22mm FLAT WASHER (WZ)	19
32	013-0702001	NYLON WASHER .38" I.D. X 1.00" O.D. X .06" THK	1
33	013-0102029	1/4" SPLIT WASHER (WZ)	4
34	013-0102020	3/8" SPLIT LOCK WASHER (WZ)	2
35	013-0102022	3/8" INTERNAL LOCK WASHER	5
36	021-0003573	COMMERCIAL MAINTENANCE DECAL	1
37	021-0003221	DECAL HOIST 2.50" X 9.13"	1
38	021-0003230	DECAL HOIST 1.63" X 5.93"	2
39	SERIAL # DECAL	DECAL SERIAL # 1.63" X 2.63"	1
40	021-0003344	ROC-IT WARNING DECAL	1
41	021-0003405	ROX DECAL	1
42	021-0003552	ROC-IT DOMED DECAL	1
43	021-0018022	HOISTFITNESS.COM LOGO	1
44	026-01X3036	30 LB TOP WEIGHT PLATE ASSEMBLY	1
45	026-01X2856	WEIGHT SELECTOR PIN	1
46	010-0008001	LANYARD COIL	1
47	026-01PL2200	PINETREE PLUG	1
48	026-01PL2201	Ø.749" O.D. PLASTIC SLEEVE	2
49	011-0112023	.473" X .281" SHSS (WZ)	2
50	021-0003571	ROC-IT RATIO DECAL	1

OWNER'S MANUAL

ABBREVIATIONS

BZ = Black Zinc

WZ = White Zinc

HHB = Hex Head Bolt

FHCS = Flat Head Cap Screw

BHCS = Button Head Cap Screw

SHCS = Socket Head Cap Screw

SHSS = Socket Head Shoulder Screw

OWNER'S MANUAL

BOLT SIZING CHART

5/16" HHB

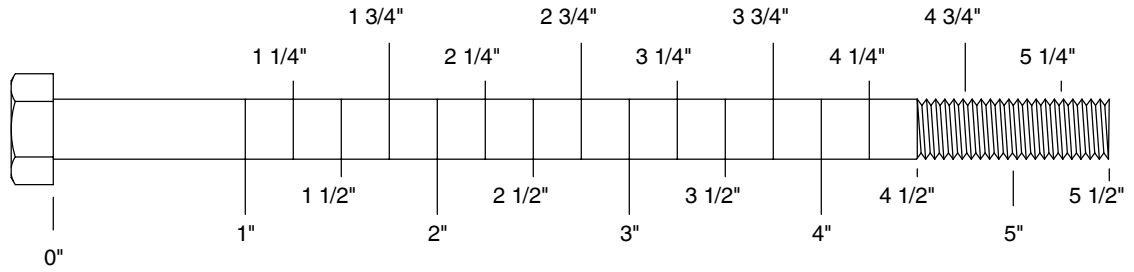
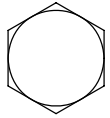

3/8" HHB

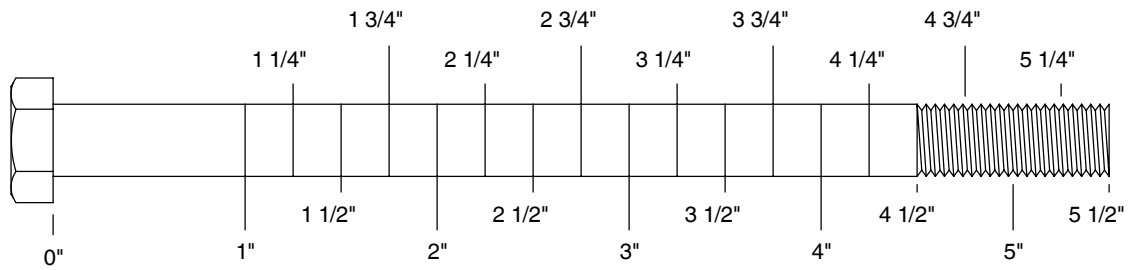
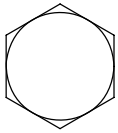

1/2" HHB

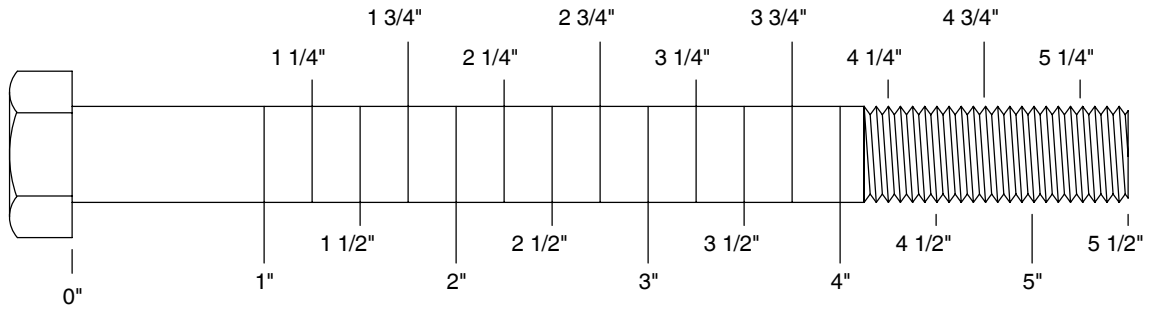
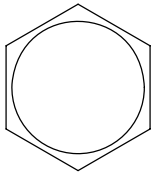

1/2" SHSS

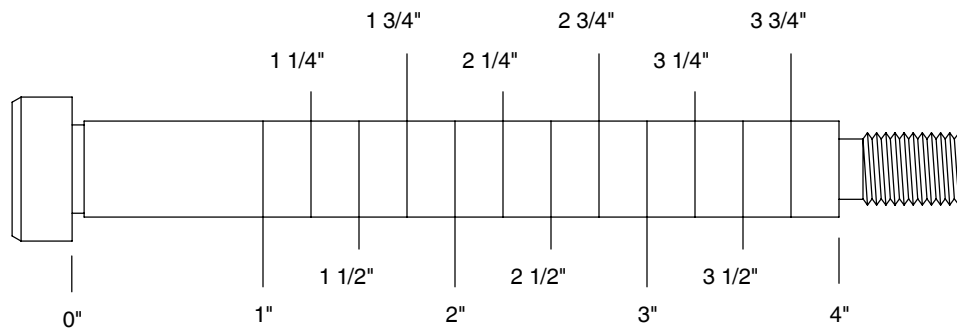
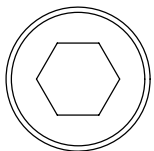

OWNER'S MANUAL

BOLT SIZING CHART (CONTINUED)

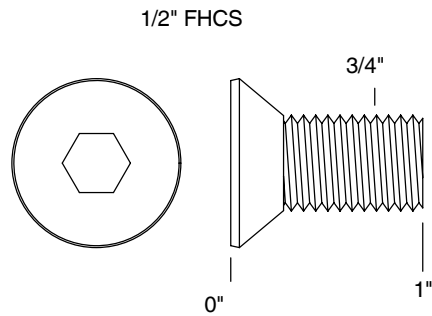
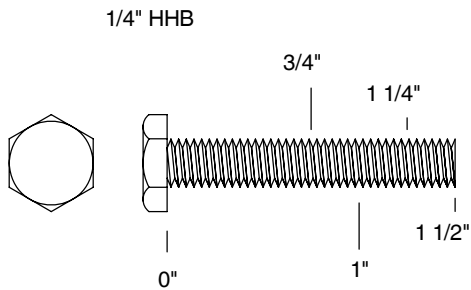
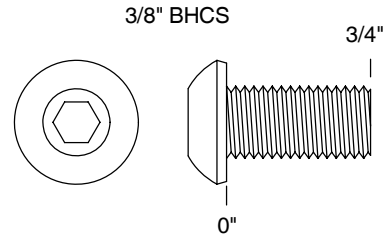
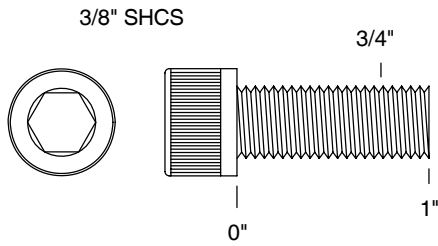
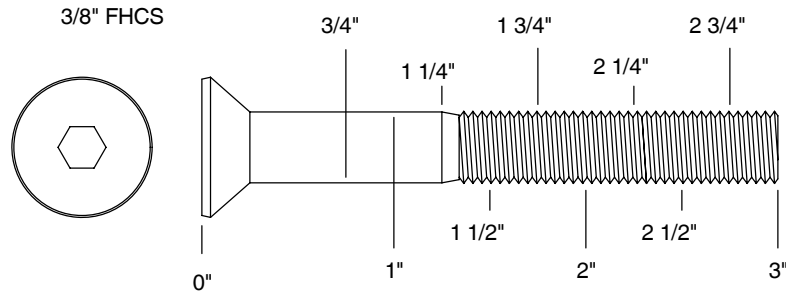

OWNER'S MANUAL

WASHER SIZING CHART

013-0002003
1/4"
FLAT WASHER
SMALL, SAE, 13mm

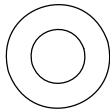

013-0102004
5/16"
FLAT WASHER
LARGE, USS, 22mm

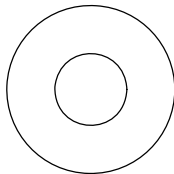

013-0002004
3/8"
FLAT WASHER
SMALL, SAE, 21mm

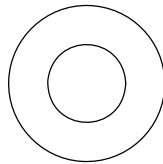

013-0402005
3/8"
FLAT WASHER
LARGE, USS, 25mm

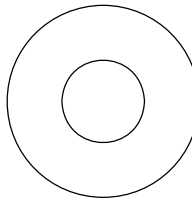

013-0102003
1/2"
FLAT WASHER
SMALL, SAE, 27mm

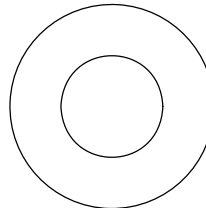

013-0102026
1/2"
FLAT WASHER
LARGE, USS, 34mm

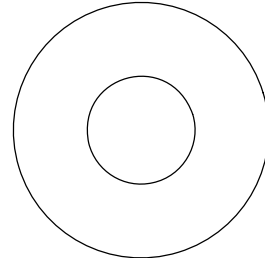

013-0102028
3/8"
CURVED WASHER

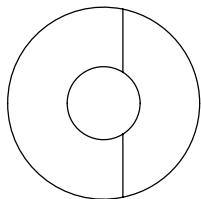

013-0402007
3/8"
FLAT WASHER
22mm O.D.

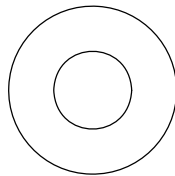

013-0102019
1/4"
LOCK WASHER



013-0102020
3/8"
LOCK WASHER

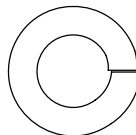

013-0102018
1/2"
LOCK WASHER

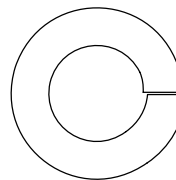

014-0018001
1/2" LONG
SPACER



026-01M0238
2" ALUMINUM
FLATHEAD CAP

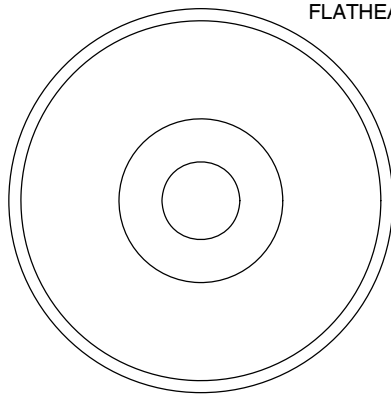

016-0009003
1" SHIM WASHER

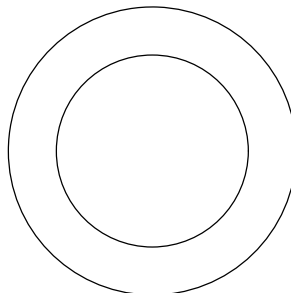

013-0003002
3/8" FENDER WASHER

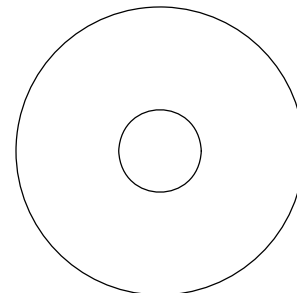

013-0003004
1 1/16"
FENDER WASHER

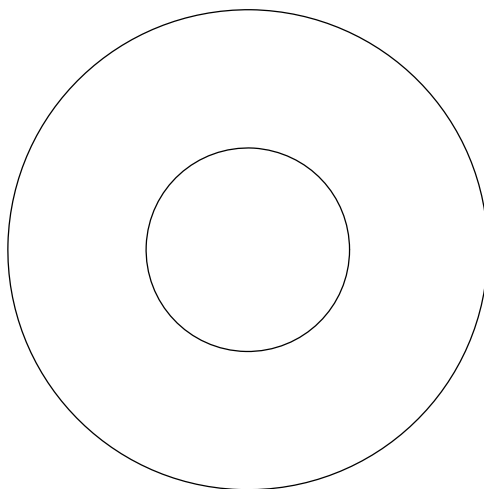

026-01PL151
PLASTIC 1 1/16"
FENDER WASHER

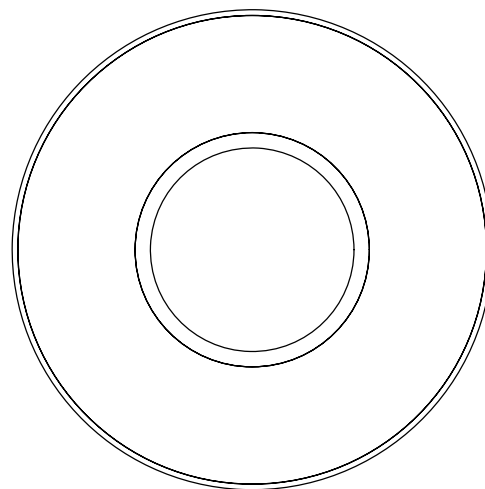

014-0018002
1" LONG
SPACER



OWNER'S MANUAL

WASHER SIZING CHART (CONTINUED)

026-01M0211
1/4" LONG
FLANGED SPACER

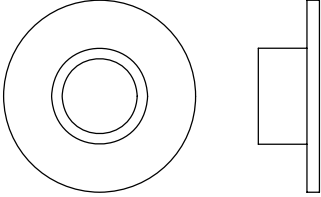

026-01M0198
1/2" LONG
FLANGED SPACER

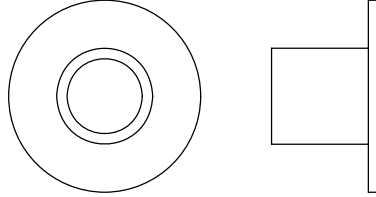

026-01M0760
1/2" LONG HEAVY
FLANGED SPACER

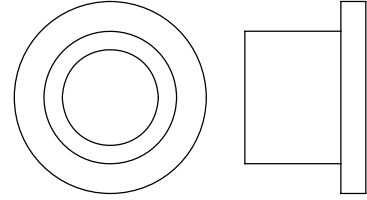

026-01M211T
1/4" LONG HEAVY
FLANGED SPACER

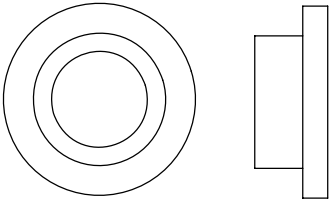

026-01M0532
11/16" LONG HEAVY
FLANGED SPACER

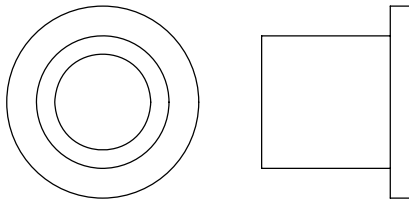

026-01M0551
1" LONG HEAVY
FLANGED SPACER

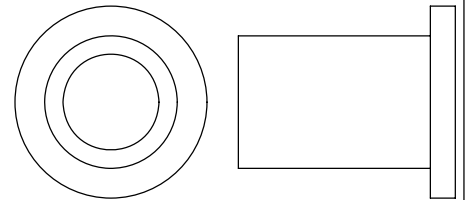

026-01M0788
.81" LONG HEAVY
FLANGED SPACER

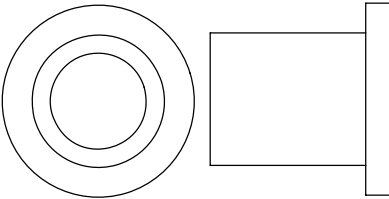

026-01M0780
.65" LONG HEAVY
FLANGED SPACER

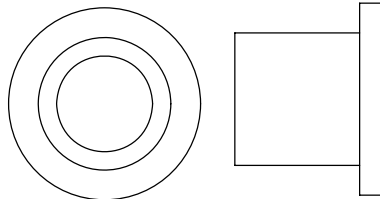

026-01M0761
1 11/16" LONG HEAVY
FLANGED SPACER

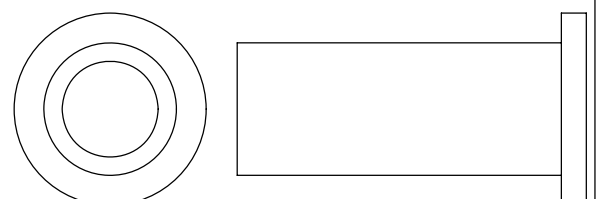

026-01M0789
.44" LONG HEAVY
FLANGED SPACER

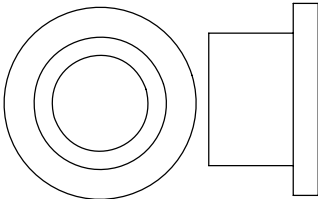

026-01M0762
1 1/2" LONG HEAVY
FLANGED SPACER

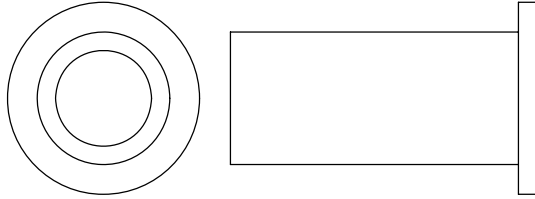

026-01M0768
1 1/4" LONG HEAVY
FLANGED SPACER

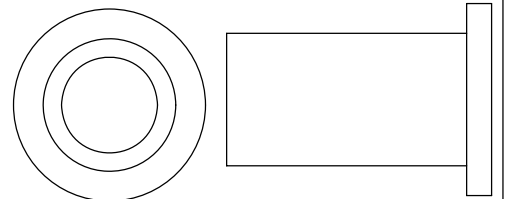

026-01M0600
.625" LONG
FLANGED SPACER

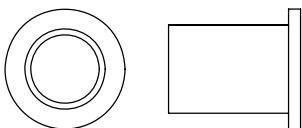

026-01M0240
1 3/8" ALUMINUM
FLATHEAD CAP

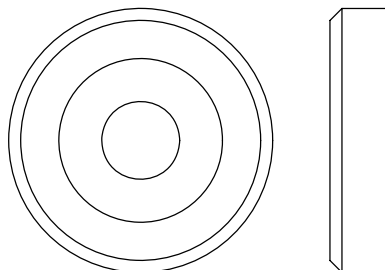

026-01M0239
1 5/8" ALUMINUM
FLATHEAD CAP

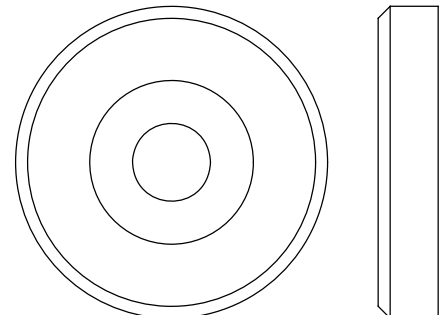

OWNER'S MANUAL

HOIST FITNESS SYSTEMS **GENERAL MAINTENANCE INFORMATION**

Links, Pull-Pins, Snap Hooks, Swivels, Weight Stack Pins:

- Check all pieces for signs of visible wear or damage.
- Check springs in snap hooks and pull-pins for proper tension and alignment.
- If the spring sticks or has lost its rigidity, replace it immediately.

Upholstery:

- To ensure prolonged upholstery life and proper hygiene, all upholstered pads should be wiped down with a damp cloth after every workout.
- Periodically take the time to use a mild soap or an approved vinyl upholstery cleaner to deter the onset of cracking or drying. Avoid using any abrasive cleaners or cleaners not intended for use on vinyl.
- Replace ripped or worn upholstery immediately.
- Keep sharp or pointed objects clear of all upholstery.

Decals:

- Inspect and familiarize yourself with any safety warnings or other user information posted on each decal.

Nuts and Bolts:

- Inspect all nuts and bolts for any loosening and tighten if needed.
- Go through a re-tightening sequence periodically to ensure that all hardware is tensioned proper.

Anti-Skid Surfaces:

- These surfaces are designed to supply secure footing and need to be replaced if they appear worn or become slippery.

Belts and Cables:

- Hoist uses only high quality belt, and mil-spec cables.
- Visually inspect the belts and cables for fraying, cracking, peeling or discoloration.
- While the machine is not in use, carefully run your fingers along the belt or cable to feel for thinning or bulging areas.
- Replace belts and cables immediately at the first signs of damage or wear. Do not use equipment until belts or cables have been replaced.

OWNER'S MANUAL

GENERAL MAINTENANCE INFORMATION

(CONTINUED)

Belt and Cable Tension:

- Referring to the Owners Manual, when belts or cables are used check all bolts attachments to be sure they are properly attached.
- Check slack in cables and re-adjust cable tension if needed.

Seat Sleeves, Guide Rods:

- Wipe down adjusting tubes with a dust free rag before applying lubricant.
- Lubricate seat sleeves and Guide Rods with a Silicon or Teflon based lubricant spray.

Linear Bearings:

- Referring to the Owners Manual carefully disassemble the bearing from its housing and place a finger full of light grease (lithium, super lube, etc.) into the inside of the bearing. Using your finger, press the grease into the ball-bearings and their tracks. repeat until the ball-bearing tracks are full of grease. Insert the shaft back into the bearing and wipe off excess grease.

PLEASE KEEP THIS FOR YOUR RECORDS

OWNER'S MANUAL

MAINTENANCE SCHEDULE

ROUTINE	COMMERCIAL MAINTENANCE	HOME MAINTENANCE	LATEST DATE ENTRY																	
Inspect; Links, Pull Pins, Snap Locks, Swivels, Weight Stack Pins	DAILY	WEEKLY																		
Clean; Upholstery	DAILY	WEEKLY																		
Inspect; Cables or Belts and their tension	DAILY	WEEKLY																		
Inspect; Accessory Bars, and Handles	WEEKLY	3 MONTHS																		
Inspect; All Decals	WEEKLY	3 MONTHS																		
Inspect; All Nuts and Bolts, Tighten if needed	WEEKLY	3 MONTHS																		
Inspect; Anti-Skid Surface	WEEKLY	3 MONTHS																		
Clean & Lubricate; Guide Rods with a Teflon (PTFE) based lubricant (Superlube)	MONTHLY	3 MONTHS																		
Lubricate; Seat Sleeves, Turcite Bushings, Linear Bearing	MONTHLY	3 MONTHS																		
Clean and Wax; All Glossy Finishes	6 MONTHS	YEARLY																		
Repack with Grease; Linear Bearings	6 MONTHS	YEARLY																		
Replace; Cables, Belts and Connecting Parts	YEARLY	3 YEARS																		

*Your equipment comes with a commercial maintenance decal.
For personal, in home use, please follow the home maintenance schedule listed above.*

OWNER'S MANUAL

WEIGHT TRAINING TIPS

Always consult your physician before starting any exercise program.

To be successful in your exercise program, it is important to develop an understanding of the basic principles of strength training. Now that you have your HOIST® Fitness System, it is only natural that you want to get started immediately. First, determine a set of realistic goals and objectives for yourself. By deciding on an exercise plan that is right for you prior to starting, you will contribute significantly to your success.

Warm up properly before engaging in weight resistance training. Stretching, yoga, jogging, calisthenics or other cardiovascular exercise can help prepare your body for the heavier workload of lifting weights.

Learn how to perform the exercise correctly before using heavy weight. Correct form is important to avoid injury and to ensure that you work the proper muscle groups.

Know your limitations. If you are new to weight training or are embarking on an exercise regimen after a long layoff, start slowly and build foundational strength over a longer period of time.

Pay attention to your breathing. Exhale when you exert is a general rule of thumb. Never hold your breath.

To gain maximum results and avoid possible injury, consult a fitness professional to develop your complete exercise program.

Enjoy your HOIST Fitness System!

OWNER'S MANUAL

WEIGHT TRAINING EXERCISE LOG

S = Sets R = Repetition per set W = Weight used

Date	S		R		W		S		R		W		S		R		W		S		R		W		S		R		W		S		R		W		S		R		W		S		R		W				
	S	R	W	S	R	W	S	R	W	S	R	W	S	R	W	S	R	W	S	R	W	S	R	W	S	R	W	S	R	W	S	R	W	S	R	W	S	R	W	S	R	W	S	R	W	S	R	W	S	R	W
Totals																																																			

OWNER'S MANUAL

HOIST FITNESS SYSTEMS **LIMITED LIFETIME WARRANTY**

Hoist Fitness Systems warrants this product to the **original purchaser** to be free from defects in workmanship and/or materials under normal use or service. If at any time a component part is defective, Hoist Fitness Systems shall repair or replace it (at Hoist Fitness Systems option) within a reasonable period of time. This warranty does not cover costs of removal, transportation or reinstallation. This warranty shall not apply if the defect was caused by misuse, neglect or normal wear and tear.

WARRANTY CLAIMS. All claims require: Model number, Serial number, Date of installation, and any information supporting the existence of the alleged defect.

**To complete Warranty Registration visit:
www.HOISTFITNESS.com
and click on the Warranty Registration link**

Starting from the original date of purchase, normal wear and tear shall be considered as the following:

COMMERCIAL USE: All malfunctions of upholstery, grips, paint, and chrome that occur after one year; all malfunctions of electronic components, belts, or **cables** after one year; all malfunctions of pulleys, bearings, or bushings that occur after five years. The frame and all welded components are warranted for the life of the product.

HOME USE: All malfunctions of grips, paint, and chrome that occur after ten years; all malfunctions of electronic components, belts, **cables**, or upholstery that occur after ten years; all malfunctions of pulleys, bearings, or bushings that occur after ten years. The frame and all welded components are warranted for the life of the product.

PLEASE NOTE THAT NOT ALL HOIST PRODUCTS ARE MADE FOR COMMERCIAL USE.

Refer to the instructions page of your owners manual or consult with you fitness product dealer to establish if a product is made for commercial use or not. Using a non-commercial product in a commercial setting can result in serious injury or death!

Hoist Fitness Systems sole responsibility shall be to repair or replace the component within the terms stated above. Hoist Fitness Systems shall not be liable for any loss or damage of any kind including any incidental or consequential damages resulting, directly or indirectly from any warranty expressed or implied or any other failure of this product.

WHAT IS NOT COVERED BY THIS WARRANTY

Hoist's sole obligation under this warranty is limited to either repair or replacement of parts, subject to the additions below. This warranty neither assumes nor authorizes any person to assume obligations other than expressly covered by this warranty.

NO CONSEQUENTIAL DAMAGES. Hoist is not responsible for economic loss; profit loss; or special, indirect, or consequential damages.

WARRANTY IS NOT TRANSFERABLE. This warranty is not assignable and applies only in favor of the original purchaser/user to whom delivered. Any such assignment or transfer shall void the warranties herein made and shall void all warranties, expressed, implied or statutory, except the one (1) and five (5) year warranties described above. These warranties are exclusive and in lieu of all other warranties, including implied warranty and merchantability or fitness for a particular purpose. There are no warranties which extend beyond the description on the face hereof.

TRANSPORTATION COSTS. Hoist will accept parts covered under this warranty freight collect, provided that shipment has received prior approval. Hoist is not responsible for any other transportation costs, but will ship freight collect parts either repaired or replaced under these warranties.

Hoist Fitness Systems
9990 Empire St. #130
San Diego, CA. 92126
(800)548-5438

PLEASE KEEP THIS FOR YOUR RECORDS